



MODEL D-57

SPECIAL CONSTRUCTION FOR CHLORINE (Cl₂) SERVICE

The following is a description of a proven construction for chlorine gas or liquid service. Units are available in sizes 1/2"-1" (DN15-25).

STANDARD CONSTRUCTION

Body.....	Carbon Steel *
Spring Chamber.....	Carbon Steel *
Flange Bolting.....	304 Stainless Steel
.....	ASTM F593 Group 1
Spring Button	Cast Iron
Range Spring.....	Epoxy-coated Steel
Pressure Plate	Cast Iron
Adjusting Screw	Stainless Steel
Jam Nut	Stainless Steel

* ASTM A216 Gr. WCB

SPECIAL CONSTRUCTION

Trim Designation No. "M3"

Plug.....	Monel with Fluorocarbon Elastomer Seat
Cylinder.....	Monel
Cylinder Gasket	PTFE
Diaphragm	Gylon 3522 (PTFE)
Pusher Plate	Monel
Body Cap	Monel
Spring	Inconel X-750

PRESSURE - TEMPERATURE RATING

Inlet: 300 psig (20.7 barg) -20 to +300°F (-29 to +149°C)

Outlet: 100 psig (6.9 barg) -20 to +300°F (-29 to +149°C)

Opt-57

Special Cleaning for Cl₂ Service per Cashco

Spec. No. S-1589.

Epoxy painted.

MODEL D-57 PRODUCT CODE 07/23/21

2D - **5** **M37** - **1** **C000000D**

BODY SIZE		CODE
in	(DN)	
1/2"	(15)	4
3/4"	(20)	5
1"	(25)	6

SPRING RANGE*		CODE
psig	(Barg)	
2 – 15	(.14-1.0)	1
10 – 40	(.69-2.8)	2
30 – 80	(2.1-5.5)	3

OPT-57

* Consult Factory for 70-150 psig spring range.

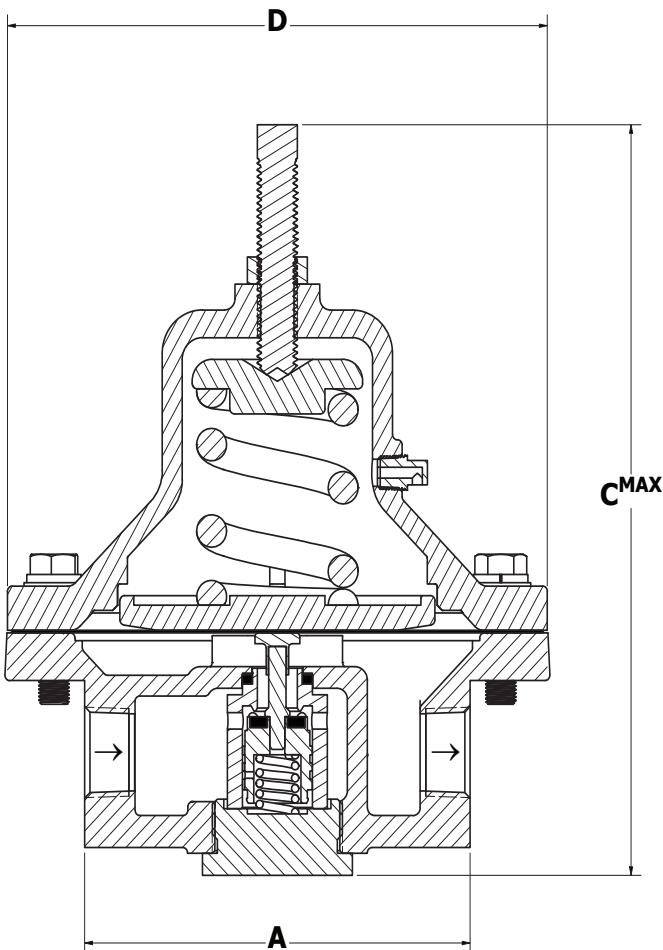

SIZE INCH	DIMENSIONS - ENGLISH (in.)			ASSEMBLED WEIGHT (lbs)
	A	C ^{MAX}	D	NON-FLANGED
1/2"	3 3/4	7 7/8	5 1/2	11
3/4"	4 13/16	8 11/16	6 3/4	17
1"	4 13/16	8 11/16	6 3/4	17
SIZE DN	DIMENSIONS - METRIC (mm)			ASSEMBLED WEIGHT (kgs)
	A	C ^{MAX}	D	NON-FLANGED
15	95	200	140	5
20	122	221	171	8
25	122	221	171	8

Cashco, Inc.
P.O. Box 6
Ellsworth, KS 67439-0006
PH (785) 472-4461
Fax. # (785) 472-3539
www.cashco.com
email: sales@cashco.com
Printed in U.S.A. D-57-TB

Cashco GmbH
Handwerkerstrasse 15
15366 Hoppegarten, Germany
PH +49 3342 30968 0
Fax. No. +49 3342 30968 29
www.cashco.com
email: germany@cashco.com

Cashco do Brasil, Ltda.
Al.Venus, 340
Indaiatuba - Sao Paulo, Brazil
PH +55 11 99677 7177
Fax. No.
www.cashco.com
email: brazil@cashco.com