

## IOM Ramén Ball Sector Valve type KS/KSP DN 40-300



*Ramén Ball Sector Valve type KS*

*Ramén Ball Sector Valve type KSP*

### Table of contents

<b>Safety instructions</b> .....	<b>2</b>
<b>Valve material codes</b> .....	<b>3</b>
<b>Pressure and temperature limits</b> .....	<b>4</b>
<b>Installation</b> .....	<b>5</b>
<b>Maintenance</b> .....	<b>7</b>
<b>Declaration of conformity</b> .....	<b>13</b>

## Safety instructions

### WARNING!

**Risk for serious injury when valve with actuator is bench tested. Avoid handling the valve with hands or fingers inside the valve! Be very careful when handling a valve which has been in abrasive service. Worn valve can have sharp edges on ball sector and seat.**

### Function

Ramén Ball Sector Valve is made from a half ball, a ball sector, which is journal led in a valve body via two shafts. One part of the ball sector sphere is used for shut-off. The other part of the sphere has a hole with a diameter which is about 80% of the nominal valve size. The ball sector is turned 90° from fully open to fully close. Some smaller valve sizes have a more reduced orifice and operation angle as follows; DN40/32 (70°), DN40/25 (60°), DN25/15 (65°), DN25/5 (60°), DN25/A-K (72°).

### IMPORTANT!

**Valves can be used for temperatures from -40°C to +200°C (+250°C). The exact temperature range is always depending on pressure, media and sealing material. Always contact your valve supplier if pressure, media and sealing material changes. See page 4 for tables with pressure and temperature limits.**

### Valve acceptance inspection

Make sure that the valve has not been damaged during transport and that it is complying to your order. Valve body is marked with type, pressure class PN, size DN, flow arrow, material code, serial number and CE-label with category and module according to PED.

### Identification of valve

Valve size and material combination can be identified by marking code on the valve body according to the following example:

<b>PN 16</b>	= Pressure class PN
→	= standard flow direction
<b>KS</b>	= Type
<b>DN 100</b>	= Valve size DN
<b>1</b>	= Material combination as per below table
<b>EN 1.4409</b>	= Material in body
<b>A19xxxx</b>	= Serial number (where 19 is year of production)

### Check of valve size

The valve size can be checked by measuring the outlet port diameter which is the same as the valve size. The inlet flow bore diameter is always reduced to about 80% of the outlet port diameter. Sizes DN25 and 40 may be further reduced.

### Storing

Valve shall be stored in a clean and dry area preventing corrosion and fouling. It shall be operated to fully open position. Protection plates shall not be removed until the valve shall be mounted.

## Valve material codes

The valve body has a material code stamped in per following table.

Material code for type KS/KSP					
Code number	1	1A	1B	1C	1E
<b>Body (Item 1)</b>	EN 1.4409	EN 1.4409	EN 1.4409	EN 1.4409	EN 1.4409
<b>Shafts (Item 5+6)</b>	EN 1.4460	EN 1.4460	EN 1.4460	EN 1.4460	EN 1.4460
<b>Ball Sector (Item 3)</b>	EN 1.4409	EN 1.4409 + Hard chrome	EN 1.4409 + Hard chrome	EN 1.4409 + Hard chrome	EN 1.4409 + Hard chrome
<b>Seat holding ring (Item 2)</b>	EN 1.4409	EN 1.4409	EN 1.4409	EN 1.4409 + Hard chrome	EN 1.4409 + Hard chrome
<b>Seat ring (Item 10)</b>	Carbon/graphite filled PTFE	Carbon/graphite filled PTFE	Stellite	Stellite	Stellite deep execution
<b>Shaft bearing (item 9)</b>	Standard= modified TFE (LR) Special= SST/PTFE compound (MP)				
<b>Shaft sealing type KS o-ring (Item 13+14)</b>	Viton	Viton	Viton	Viton	Viton
<b>Shaft sealing type KSP, stuffing box (Item 13)</b>	PTFE	PTFE	PTFE	PTFE	PTFE
<b>Seat back-up o-ring (Item 15)</b>	Viton	Viton	Viton	Viton	Viton

<b>Seat back-up spring &amp; seal ring (Item 15A+15B)</b>	EN 1.4460/PTFE	EN 1.4460/PTFE	EN 1.4460/PTFE	EN 1.4460/PTFE	EN 1.4460/PTFE
<b>Sealing between inlet cover ring and body (Item 16)</b>	Viton	Viton	Viton	Viton	Viton
<b>Valves supplied with other o-ring material than Viton has material code suffix:</b>	(EP)=EPDM (KKT/KTT)= Kalrez/Vitoflon (FS)=Fluor Silicon (AF)=Aflas (X)= Other quality				

## Pressure and temperature limits

Temperature related max working pressure in [bar] for material EN 1.4409:

PN	-40°C	+20°C	+50°C	+75°C	+100°C	+150°C	+200°C	+250°C
PN10	10	10	9	8,5	8	7,5	7	7
PN16	16	16	14,5	13,5	13	12	11,5	11
PN25	25	25	23	21,5	20,5	19	18	17,5
PN40	40	40	37	35	33	31	29	28

All values in [bar] if nothing else stated

### Temperature limits for seat- and sealing material

Material	O-ring seals (Type KS)					Seat ring (Type KS / KSP)		Shaft Sealing (type KSP)
	Viton	Viton GLT	EPDM peroxide	Kalrez	Vitoflon	PTFE carbon/graphite filled	Stellited SST	PTFE braid
<b>Min temperature</b>	-10°C	-40°C	-20°C	-10°C	-10°C	-40°C	-40°C	-40°C
<b>Max temperature</b>	+170°C	+170°C	+120°C (+140°C)	+200°C (+250°C)*	+200°C	+170°C	+200°C (+250°C)*	+250°C

\*with shaft bearing material MP (option)

### Temperature limits for shaft bearing material

Material	Standard (type LR)	Option (type MP)
Min temperature	-40°C	-40°C
Max temperature	+200°C	+250°C

### Attention!

The temperature limits for sealing material varies depending on which type of media and pressure it will be exposed to. Contact the manufacturer of sealing material or your valve supplier in all cases of hesitation.

## Installation

### Valve actuator

The valve is normally equipped with an actuator. Depending on the application it can be a hand lever or a remotely controlled pneumatic or electric actuator. The actuator may have limit switches (on-off application) or positioner (continuous control).

### Installation

**This product shall only be inspected, installed and used by a person who has relevant training or experience. If any questions or hesitation, contact your valve supplier or Ramén Valves AB.**

If the valve shall be equipped with actuator this shall be done before installation in the pipe line. Separate instruction is supplied on request.

Before installation of the valve, check that the valve data is in conformity with actual type of service with reference to media, pressure and temperature.

**If the valve shall be used as shut-off valve against atmosphere at the end of the pipe, where possible leakage can cause person injury or property damage, there are special limits for max working pressure and, if necessary, demands on blocking the actuator. Contact your valve supplier.**

Piping shall be thoroughly cleaned. Check that the pipe flanges are parallel and that the piping system can not be subject to uncontrolled forces caused by pressure peaks, or pipe forces caused by variations in temperature.

The valve shall be operated into fully open position after installation and the pipe system be properly flushed before put into service.

### IMPORTANT!

Install the valve in such position that injury on person, or damage on property, is avoided in case of leakage from sealing or flange joints. Also, make sure that, in case of leakage, inflammable media do not come in contact with electrical components or hot surfaces which can cause fire or damage on property.

### Valve position indication

The actual position of the ball sector can be defined on the lower shaft end, opposite to the actuator:

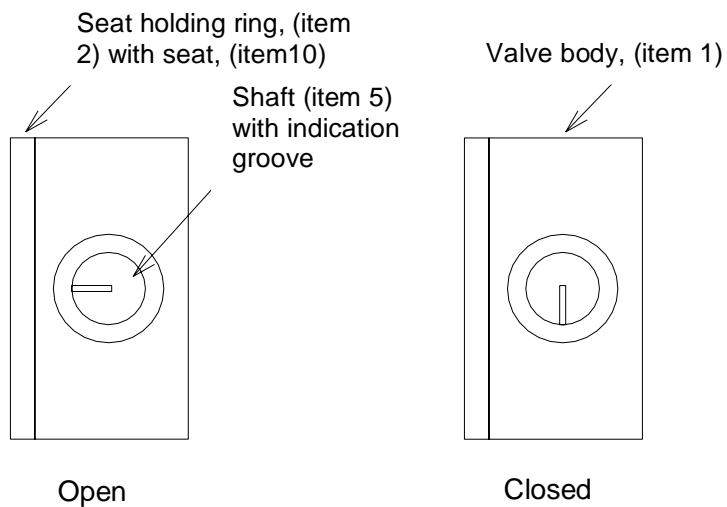

### Flow direction

The valve's performance is equal regardless of flow direction. Although it is recommended that the valve is mounted according to the flow direction arrow.

### Startup

The valve shall be operated and controlled that closing- and opening functions are correct before start-up. Check that the valve operates within its max- and min-positions. Limit-switches, positioner, feed-back signal and torque switches shall be checked for correct function.

Start-up shall be done gradually and under careful attention. If water hammer, leakage, cavitation or noise occurs in the system they have to be eliminated before they cause any harm.

### Dismounting from pipeline

Before the valve is dismantled from the pipe, all wiring in form of power supply and control signals as well as supply air has to be disconnected. If the valve is equipped with spring closing/opening actuator thoroughly check that the valve has taken its fully closed or opened position.

### **Attention!**

**Check that the pipe is depressurized and drained. Great caution must be taken when there is a risk for toxic or corrosive media is captured in the valve!**

## Maintenance

Ramén Ball Sector valve requires no lubrication and a minimum of maintenance. If any part of the valve should become damaged it can be replaced by a spare part. Spare parts are obtained from the valve distributor. Any spare parts order must indicate valve type (KS), size (DN), material combination and item number according to the spare parts list.

**Disassembly**

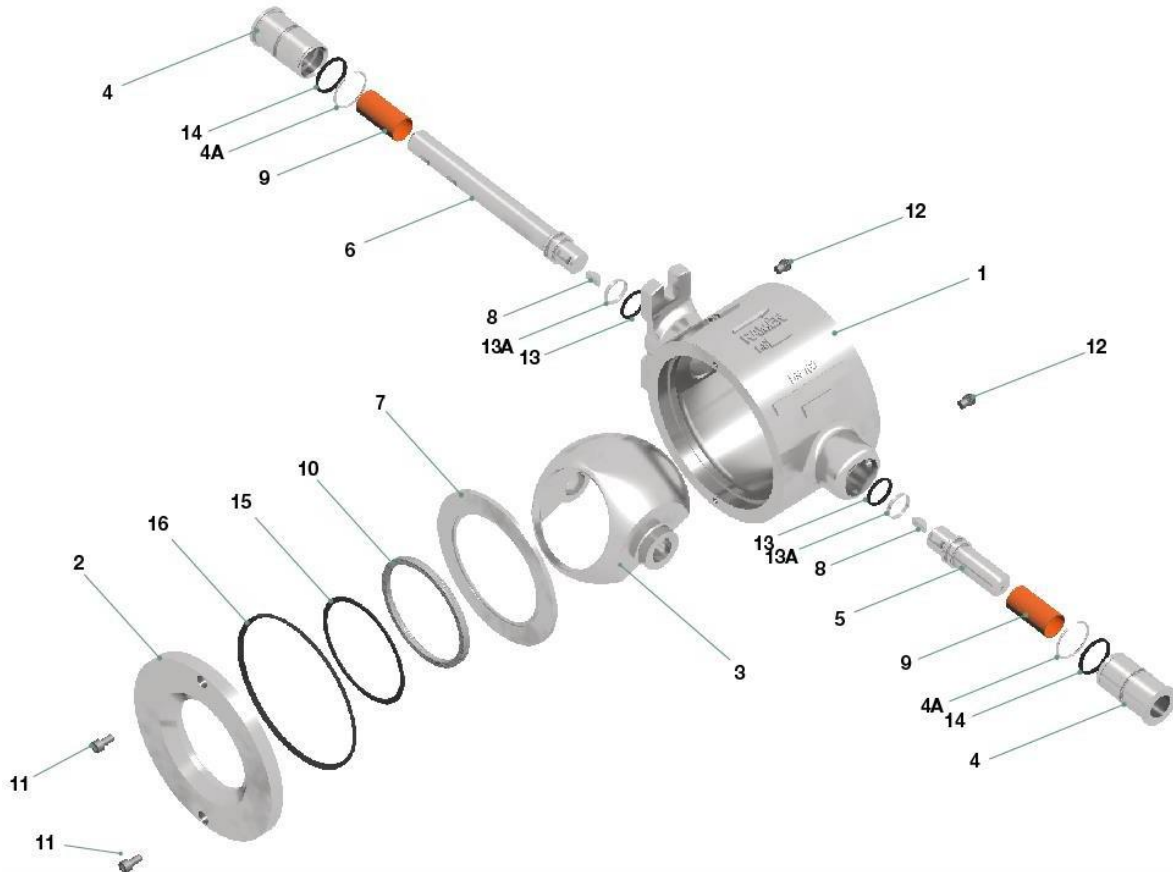

**DN 40-50 (1½"-2")**

- a) Loosen screws (11) and inlet cover ring (2)
- b) Lift out seat ring (10) carefully from its groove using a pointed tool. and the O-rings (15 och 16).
- c) Lift out seat support ring (7).
- d) Loosen locking rings (18) and washer (17) at both trunnion shaft ends.
- e) Push the ball sector slightly so that the locking ring, 4A, can be removed using a small screw driver. Pull out trunnion shaft (6) by fastening it in a jaw vice and then knocking on the actuator flange on the valve body.
- f) Push out trunnion shaft (5) by means of a rod inserted through the shaft hole.
- g) Remove Rulon bearing (9) from the shafts.
- h) Remove O-rings (13 and 14). Be careful not to damage sliding ring (13A). See "Reassembly"



### DN 80-250 (3"-10")

- a) Loosen screws (11) and inlet cover ring (2)
- b) Lift out seat ring (10) carefully from its groove using a pointed tool and the O-rings (15 and 16).
- c) Lift out seat support ring (7).
- d) Loosen locking rings (12) enough to loosen the bearing sleeves (4). Push the ball sector slightly so that the locking ring, 4A, can be removed using a small screw driver.
- e) Pull out the bearing sleeves (4) from the shafts and out of the valve body, and/or trunnion shaft (6) by fastening it in a jaw vice and then knocking on the actuator flange on the valve body.
- f) Push out trunnion shaft (5) and eventually the sleeve (4) by means of a rod inserted through the shaft hole.
- g) Remove Rulon bearing (9) from the shafts.
- h) Remove O-rings (13 and 14). Be careful not to damage sliding ring (13A). See "Reassembly"

### Reassembly

Proceed in reverse order. O-rings (13, 14 15 and 16) shall be lubricated with suitable grease before reassembling. Please note "Important when assembling" below. If the o-rings show sign of wear or other damage, check if the most appropriate o-ring material has been used. Check the sliding ring (13A) replace if necessary. The sliding ring is not necessary for the valve function but will increase the efficiency and life of the shaft seal. Proper mounting of the sliding ring may be done only with the appropriate tool as shown in fig 2.

#### **DN 40-50 (1½"-2"), reassembly is done in reverse order.**

Sliding ring (13A) can only be mounted with the tool shown in fig 2. When O-ring (13) has been placed in its groove on the shaft (5) and drive shaft (6) and then pushed into the groove great care must be taken not to damage the o-ring. Fig. 3 shows a suitable method and dimensions on a tool that will protect the O-ring (13) and Rulon bearing (9) when assembling.

Check that the locking ring (4A) is undamaged and kept in some tension in its groove after reassembly. Change ring if necessary.

#### **DN 80 - 250 (3"-10"), reassembly is done in reverse order.**

Sliding ring (13A) can only be mounted with the tool shown in fig 2. Carefully push the bearing sleeve (4) with the O-ring (14). When the O-ring passes the drilled hole for the stop screw (12) it might be pressed into the hole with risk for damage. Check that the hole is free from sharp edges or burrs. When the O-ring passes the hole it can be pushed back from outside with a blunt end pin.

Check that the locking ring (4A) is undamaged and kept in some tension in its groove after reassembly. Change ring if necessary.

### After reassembly

Pressure test the valve with air from the valves outlet side and with the valve closed. The valve immersed in water or with leakage spray shall be bubble tight over shaft seals and seat. I small bubbles can be detected around the shafts it can be enough to actuate the valve a few times allowing the O-rings to find its correct position. If the valve still leaks the o-ring has been damaged and must be changed. Valves with PTFE-seat shall be bubble tight in both directions. Valves with stellited seat will never be bubble tight. These valves can be tested with water. Max leakage for a new valve is 0,01% of the valves  $C_v/K_v$  s-value.

### Mounting actuator on the valve

See separate document "Instruction and guidelines for mounting of pneumatic actuator on Ramén Ball Sector Vavles type KS (1907)". The document can be provided by your valve supplier.

### Assembly tools

Tools for assembly of O-ring and sliding ring. Dimensions specified in mm.

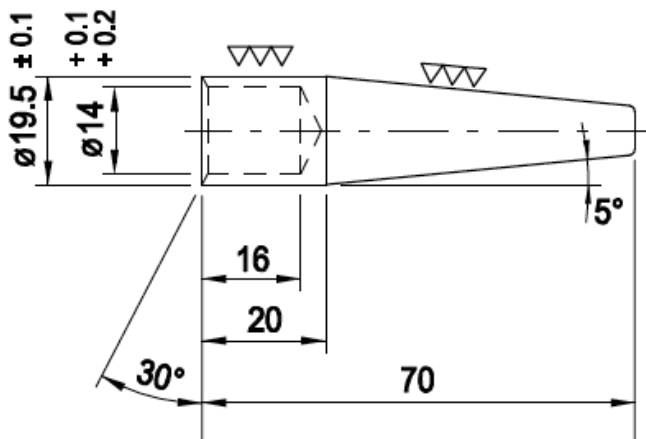

**DN 40**  
**DN 50**

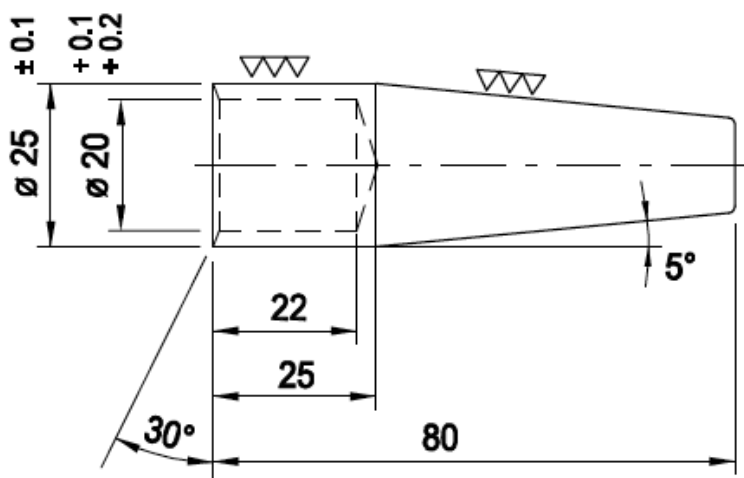

**DN 80**  
**DN 100**

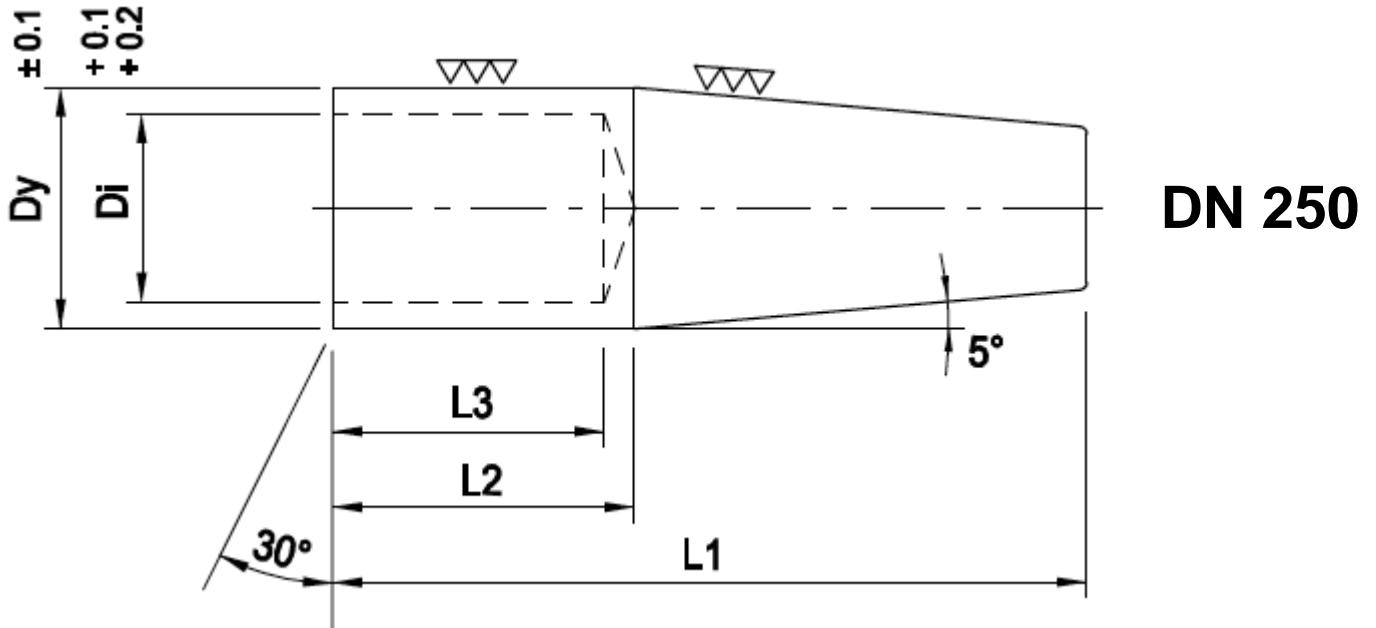

Valve size	Dy	Di	L1	L2	L3
DN 150-200	32	25	100	40	36
DN 250	38	32	110	45	42
DN 300	50	40	130	60	55

**How to use the tool**

13A = sliding ring

13= O-ring

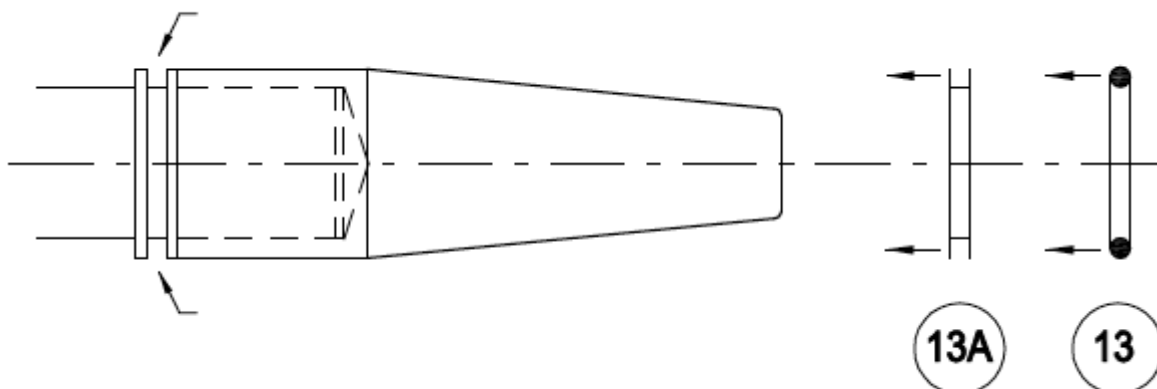

**Tool for mounting shaft and drive shaft**

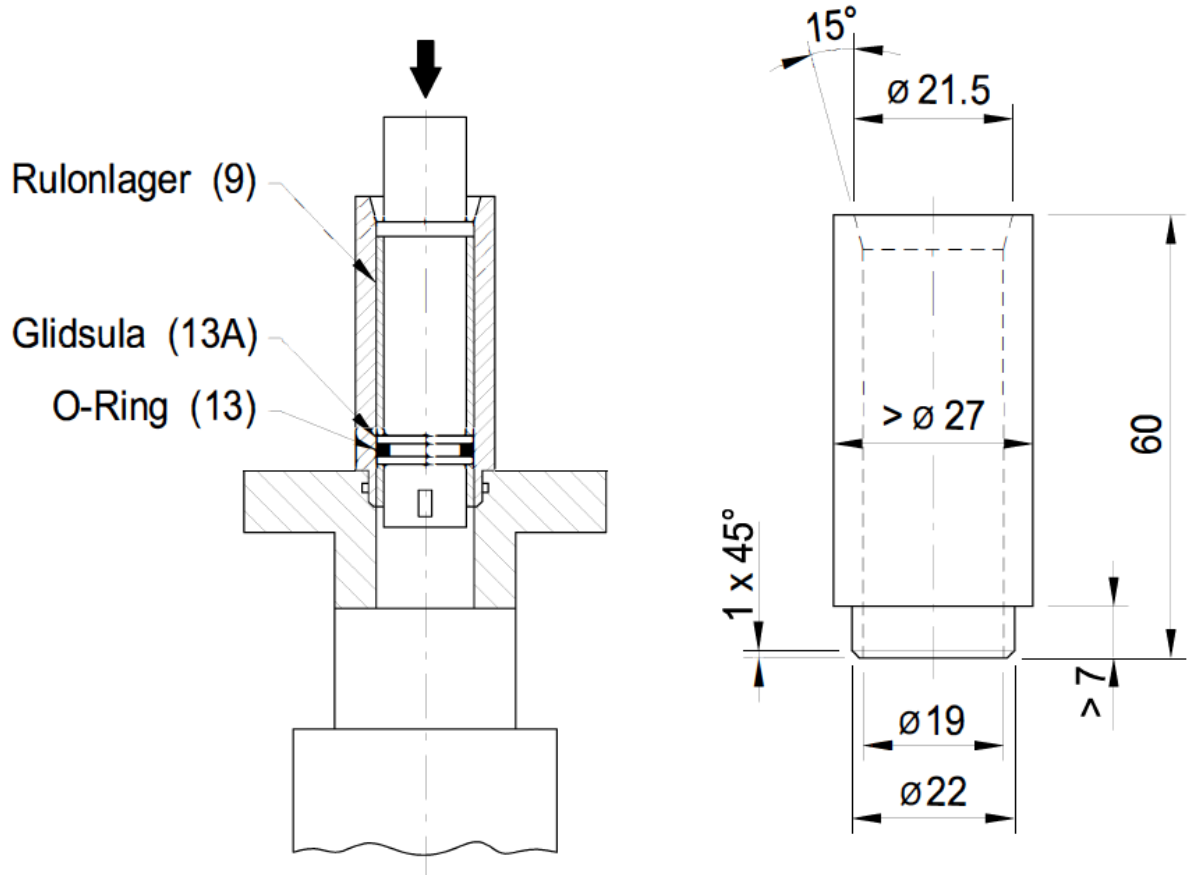

## EU-DECLARATION OF CONFORMITY

according to the  
PED 2014/68/EU

Type of equipment: Ball Sector Valve  
Make: Ramén Valves AB  
Brand name: Ramén KS  
Dimensions: DN40-DN300

### Manufacturer

Ramén Valves AB  
Fredsforsstigen 22 A  
168 67 Bromma

The annex indicates the documents used for verification of conformity

### Additional information pressure equipment PED 2014/68/EU

The following conformity assessment procedure has been applied:

Module D1 (quality assurance of the production process), Cert.no: K1701644

DEKRA Industrial OY, -0875, P.O. Box 41 FI-01621 VANTAA

As manufacturer, we declare under our sole responsibility that the equipment follows the provision of the Directive stated above.

Bromma 2017-10-30

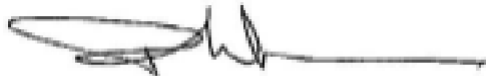

---

Per Wennersten  
QA

### Annex to the DECLARATION OF CONFORMITY

The following standards have been applied:

EN 12516-2

EN 10 204

EN 10213:2007

EN 12266-1, EN 60534-4

Allowable Stresses

Material certificate

Material Standard

Test procedure