



ISO Registered Company



Model 2296

MODEL 2296 /

2296HF

("HF" Formerly 1-1/2" & 2" Model 2266)

SST and Bronze

Pneumatic or Electric Actuated
Control Valve

The Model 2296 / 2296HF is an inexpensive stainless steel or bronze globe-style, control valve for plant utility and process applications. It is available with multiple characteristics. Model 2296 - Sizes include 1/2", 3/4", 1", 1-1/2" and 2" (DN 15, 20, 25, 40 and 50).

Model 2296HF - Sizes 1-1/2" and 2" (DN40 and 50).
Cast Bronze material only.

FEATURES

- Quick change trim.
- Equal percent or linear characterization.
- If replacing an existing Model 2266 with a Model 2296 select linear flow characteristic (trim).
- Std. wetted trim components of 316 or 316L SST.
- Metal or TFE soft seat.
- SST or BRZ body.
- Full or reduced port trim.
- Standard Actuator compliant with IEC 60534-6-1 for mounting standardized positioners.
- Rotork Electric Actuator available in 110v AC or 24v DC, aluminum water tight enclosures. Comes standard with Hart protocol.

APPLICATIONS

Model is capable of handling air, gases, oils, water, oxygen, steam and many corrosive process fluids. With optional construction it is suitable for cryogenic service.

STANDARD / GENERAL SPECIFICATIONS

Body Sizes: 1/2", 3/4", 1", 1-1/2" and 2".
(DN15, 20, 25, 40, and 50).
Model 2296HF available in 1-1/2" & 2".
(DN40 and 50) Cast Bronze only.

Body Material Cast 316L SST or Cast Bronze.

Max. Allowable Working Press: See Table 1.

Working Temperature Range: Standard: -20°F to +400°F, (-29°C to +204°C).
Option -36: -425°F to +400°F, (-253°C to +204°C).
Option -5, 5N: -325°F to +400°F, (-198°C to +204°C).

End Connections: Female NPT.
Opt-30: SST 150#, 300#, 600# RF Flange for use on SST body material. F-to-F dimensions per ANSI/ISA 75.08.01
Opt-32: Extended Nipple, Schedule 80, plain end.

Max. Shutoff Press: See Table 2.

Seat Leakage: Meets ANSI/FCI 70-2.
Metal Seated – Class IV
TFE Soft Seated – Class VI.

Flow Direction: Standard: Flow-to-Open (FTO). Minimizes packing sealing pressure level. (Not recommended for Flow-to-Close direction.)

Inherent Flow Characteristic: Equal Percent (=%) or Linear; FTO direction only.

Rangeability:

Port/Seat Description	Rangeability	
	Seat Leakage Class	
	IV	VI
Full - Metal	50:1	–
Full - Soft	–	50:1
Reduced - Metal	50:1	–
Reduced - Soft	–	25:1

Painting: Standard – All non-corrosion resistant portions are powder coated per Spec. S-1743 and/or with corrosion resistant epoxy paint per Cashco Spec #S-1606.

Alternate: – See Opt-95

Flow Capacity: Per ISA S75.11.

MODEL 2296					
Size		Port - Orifice		Max Cv Seat Design	
inch	(DN)	Description	Character	Metal	Soft
1/2"	(15)	Full	Equal %	8.8	7.1
			Linear	9.7	7.6
		Reduced	Equal %	3.5	3.7
			Linear	3.5	3.5
3/4"	(20)	Full	Equal %	11.2	9.2
			Linear	11.2	9.8
		Reduced	Equal %	3.7	3.8
			Linear	3.6	3.6
1"	(25)	Full	Equal %	12.0	11.5
			Linear	12.0	11.5
		Reduced	Equal %	3.8	3.9
			Linear	3.6	3.9
1-1/2"	(40)	Full	Equal %	18.5	18.5
			Linear	18.5	18.5
		Reduced	Equal %	9.6	9.6
			Linear	9.2	9.3
2"	(50)	Full	Equal %	39.0	39.0
			Linear	38.6	38.6
		Reduced	Equal %	27.3	28.2
			Linear	26.9	27.9
Model 2296HF CAST BRONZE ONLY					
1-1/2"	(40)	Full	Equal %	22.5	22.5
			Linear	26.0	25.2
		Reduced	Equal %	10.0	10.1
			Linear	9.7	9.8
2"	(50)	Full	Equal %	44.5	44.5
			Linear	44.0	44.0
		Reduced	Equal %	29.6	30.7
			Linear	28.8	30.1
See Tables 4, 5, 6 & 7 for Cv at 10% Travel Increments					
METRIC CONVERSION FACTOR: Cv / 1.16 = kv					

Actuators: Spring-Diaphragm Type - Reversible.
ATC-FO = Air-to-Close, Fail Open;
ATO-FC = Air-to-Open, Fail Close.

Basic Actuator Model No.	Body Sizes		Action
	inch	(DN)	
C27 & C53	1/2" - 2" (15-50)		Reverse; ATO-FC (Increase in air "LOAD" retracts actuator stem.)
C27 & C53	1/2" - 2" (15-50)		Direct; ATC-FO (Increase in air "LOAD" extends actuator stem.)

See Table 2 for proper selection of required bench setting range spring.

Electric Actuators: Rotork actuators available in 110v AC or 24v DC, aluminum water tight enclosures. Comes standard with Hart protocol.
CML 750: water tight IP67, NEMA 4 & 6, CSA 4 & 6, standard manual override.

CVL 1500: water tight IP68, NEMA 4 & 6, CSA 4 & 4x, blue tooth, optional manual override.

Consult factory on other protocols, enclosures or options. See Table 3.

NOTE: If electric actuator is selected, all other accessories in positions 12 through 15 of the coder are not available, must select "0" in the product coder for these positions.

BODY SUB-ASSEMBLY SPECIFICATIONS

Body/Bonnet Materials: BRZ / BRZ
316L SST / SST

Trim: 18-8 SST material or better.

Seat Design	Trim Designation No.	Service
Metal	S1, MB1	Standard & Cryogenic
TFE - Soft	S3, MB3	Standard & Cryogenic
See Table A for complete trim material specifications.		

Stroke:

Body Size		Travel/Stroke	
inch	(DN)	inch	(mm)
1/2"-1-1/2"	(15-40)	.500"	(12.7)
2"	(50)	.750"	(19.0)

Gaskets: Body-to-Bonnet: TFE (Standard); Spring Loaded TFE (Cryogenic).
Seat Ring: Fluorogold (TFE) (Standard and Cryogenic).

Bonnet Bolting: 2" (DN50) body size only. All bolting zinc-plated alloy steel.

Standard Construction - Zinc plated
Studs: ASTM A193, Gr. B7;
Nuts: ASTM A194, Gr. 2H.
Opt.-36, -5 and -5N Cryogenic Construction - SST
Studs: ASTM A193, Gr. 8; Cl.1;
Nuts: ASTM A194, Gr. 8/8B.

Stem Packing Apparatus:

Packing – All packing ring sets are complete with upper and lower TFE adapters; V-rings of virgin TFE, non-split.
Bolting – 18-8 SST studs and nuts.
Flange – 316 SST.
Follower – 316 SST with SST Body and Brass with Bronze Body.

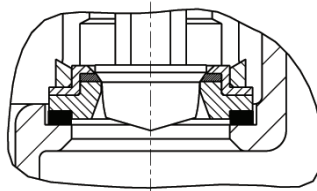

Figure 1
TFE-Soft Seat Design

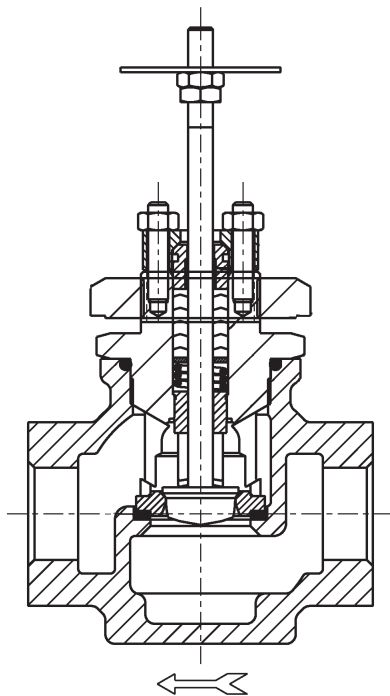

Figure 2
Model 2296 Sizes 1/2"-1-1/2" (DN15-40)
Metal Seat

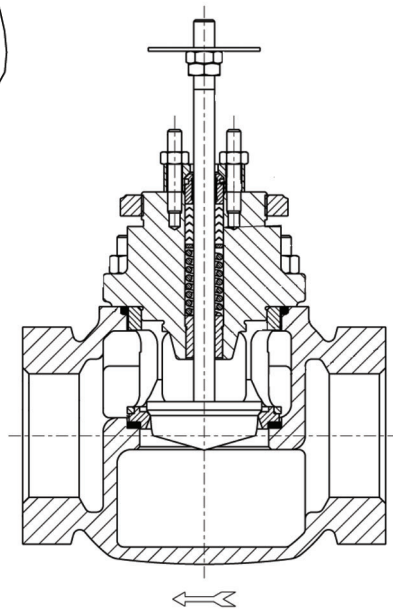

Figure 3
Model 2296 Size 2" (DN50)
Metal Seat

PNEUMATIC ACTUATOR SUB-ASSEMBLY SPECIFICATIONS

Size, Stroke & Volumes:

Basic Actuator		Dia-phragm Area		Nominal Stroke		Volumes			
						Clearance		Displacement	
Model	Action	in ²	(cm ²)	in	(mm)	in ³	(cm ³)	in ³	(cm ³)
C27	ATC	32	(209)	0.5	(12.7)	30.3	(496.5)	16.2	(265.5)
	ATO					28.2	(462.1)	16.4	(268.7)
	ATC			0.75	(19.05)	25.8	(422.8)	25.4	(416.2)
	ATO					24.4	(399.8)	24.1	(394.9)
C53	ATC	53	(342)	0.5	(12.7)	46.1	(755.4)	28.2	(462.1)
	ATO					44.3	(725.9)	24.7	(404.8)
	ATC			0.75	(19.05)	38.4	(629.3)	39.3	(644.0)
	ATO					36.9	(604.7)	39.0	(639.0)

Bench Set & Max/Normal Pressures:

Bench Set		Air Pressures			
		Normal Supply		Design Max.	
psig	(Barg)	psig	(Barg)	psig	(Barg)
5-15	(0.34-1.03)	20	(1.4)	100	(6.9)
15-60	(1.03-4.14)	75	(5.2)	100	(6.9)

Ambient Temperature: -50° to +180°F (-45° to +83°C).
-20° to +140°F (-29° to +60°C) with electrical accessories.

Materials:

Part	Material
Diaphragm	Buna-N w/Polyester Insert
Lower & Upper Case, Yoke	Steel
Attachment Hub	17-4 PH SST
Stem	316/316L SST
Diaphragm Plate, Stem Spacer, Spring, Spring Plate, Hub Nut, Stem Bolt,	Steel
Diaphragm Washer	316/316L SST
Diaph. Washer O-ring, Hub O-ring, Stem O-ring	Buna-N
Bolts & Nuts	Steel Plated
Stem Lock Washer,	Steel

OPTION SPECIFICATIONS

Option -3:

MANUAL HANDWHEEL. Overrides the actuator spring force to allow manual stroking of the valve. Single acting design, side-mounted, handwheel. For ATO-FC action, handwheel operator "opens" the valve against spring force; may be utilized as a travel stop to prevent full closure. For ATC-FO action, handwheel operator "closes" the valve against spring force; may be utilized as a travel stop to prevent full opening.

Option -5N_:

CRYOGENIC CONSTRUCTION. Bronze Body only for **non-oxygen service**. For gaseous "G" or liquid "L" cryogenic services in an applicable temperature range of -325 to +400 F (-198 to +204 C). Includes extension column and internally live-loaded TFE packing. Cleaned per Specification #S-1542.

Option -5_:

CRYOGENIC CONSTRUCTION. Bronze body for gaseous "G" or liquid "L" services in an applicable temperature range down to -325° to +400°F (-198° to +204°C). See Table 1. Includes extension column, and internally live-loaded TFE packing. Cleaned and packaged for **oxygen service** per Specification #S-1134.

Option -36_:

CRYOGENIC CONSTRUCTION. SST body for gaseous "G" or liquid "L" services in an applicable temperature range down to -425° to +400°F (-253° to +204°C). See Table 1. Includes extension column, and internally live-loaded TFE packing. Cleaned and packaged for **oxygen service** per Specification #S-1134

Model	Body Size		Extension Column Length		Recommended for _____
	inch	Cryogenic OPT-	inch	(mm)	Applications
2296/ 2296HF **	1/2"-1"	5NG,5G,36G	5"	(127)	Gaseous
		5NL, 5L, 36L	12"	(305)	Liquid
	1-1/2"	5NG,5G,36G	5"	(127)	Gaseous
	1-1/2"-2"	5NL, 5L, 36L	15"	(381)	Liquid *

* May also be used in Gaseous Applications
** Model 2296HF only available in 1-1/2" & 2" sizes

Option -12:

REDUCED ORIFICE. For reducing the maximum flow rate, or for handling higher pressure drops than the standard orifice will handle.

Option -15:

STELLITED TRIM. Stellite seat ring and plug, metal to metal seats, full port only.

Option -40:

NACE CONSTRUCTION. Internal wetted portions meet NACE STD. MR0175 for applications in sour gas/crude oil service. SST body and trim only.

Option -55:

SPECIAL CLEANING. Cleaned and packaged per Cashco Specifications #S-1134. Suitable for oxygen service.

Option -56:

SPECIAL CLEANING. Special cleaning procedure per Cashco Specifications #S-1542. Suitable for fluids other than oxygen.

Option -95:

EPOXY PAINT. Special epoxy painting of all non-corrosion resistant external surfaces per Cashco Spec #S-1547. Utilized in harsh atmospheric conditions.

MOUNTED ACCESSORY SPECIFICATIONS

Positioners: General: PMV Positioners. Aluminum housing with corrosion resistant powder coated epoxy. Pneumatic output load as required by actuator bench range. Field reversible action. Mounting dimensions per IEC 60534-6-1 Standard.

P/P Pneumatic. Model P5 features SST cam with a simple cam locking device, tapped exhaust port for venting media, external zero adjustment. Input signal 3-15 psig, Includes gauge ports, no gauges. Analog only.

I/P Electro-Pneumatic. Model D20 Digital or Hart compatible. Features single button self-calibration. input signal 4-20mA. Optional gauge block with gauges for Models D20 D and D20 I.

Model D20 D is general purpose.

Model D20 I is Intrinsically safe, ATEX Ex ia IIC T4, FM CLS 1 DIV 1, FM Non-incendive CLS 1 DIV 2.

Model D20 E is ATEX EEX d IIB+H₂, T6 FM Approved. Gauge block is built in, no gauges. Not available with limit switch option.

Model D3 Digital, Hart, Profibus, or Fieldbus compatible. Input signal 4-20mA. Features large graphic display. Optional gauge block for Models D3 X and D3 I, no gauges.

Model D3 X is general purpose.

Model D3 I is Intrinsically safe, ATEX EEX ia IIC T4.

Model D3 E is ATEX EEX d IIB+H₂, T6 CSA CLS 1 DIV 1 FM CLS 1 DIV 1

Gauge block is built in, no gauges. Not available with limit switch option.

Model PS2 is Hart, Fieldbus and Profibus compatible. Input signal 4-20mA. Features a Makrolon housing, (Aluminum for Explosion Proof.) Mounting dimensions per IEC 60534-6-1 Standard.

Model PS2-1 is general purpose.

Model PS2-2 is Intrinsically safe, ATEX Ex ia IIC T6/T4, FM CLS 1 DIV 1, CSA CLS 1 DIV 1, SIL 2

Model PS2-3 EX d IIC T6/T4, SIL 2

All I/P positioners not available with 764's.

Air Tubing: Instrument air tubing SST with SST fittings.

Airset: Model 5200P instrument air supply regulator. Use with positioners. Bracket mounted to actuator casing. Supplied with gauge. See technical bulletin 5200P-TB.

Solenoid Valve: Standard Brass: Available in standard weather-proof model. Brass body, 1/4" female NPT connections. Nipple mounted to actuator casing. 120 VAC, 60 Hz power supply, CSA Approved Class 3221-01, NEMA 2,3,3S,4,4X. 8" HF utilizes a direct mount NAMUR mount style.

X-Proof or SST construction: Consult Factory.

Standard installation vents actuator and drives valve to fail-safe position upon loss of electrical power.

Consult factory for 230/1/50, or 120 VDC power supplies, or intrinsically safe (IS) service.

Transducers: FM, CSA approved NEMA 4X CI 1, Div 1 and CI 1, Div 2

Other Accessories: 764 P/PD pressure controller. Lockup valve. Position transmitter.

Limit Switches: Model D20 and D3 positioners, switches are available, unit is enclosed in the positioner housing.

Limit switch not available on Explosion proof rated positioners.

**TABLE A
TRIM MATERIALS VS. DESIGNATION NOS.**

Part Description	Metal		Composition/Soft	
	S1	MB1	S3	MB3
Plug/Stem Assy.	316/316L SST	Monel	316/316L SST	Monel
Seat Ring	316/316L SST	Brass	316/316L SST	Brass
Retainer	--	--	316/316L SST	Brass
Valve Seat	--	--	TFE	
Guide Bushing	17-4PH SST	Phos Bronze	17-4PH SST	Phos Bronze
Seat Ring Gasket	Fluorogold			
Bonnet Gasket	TFE			

**TABLE 1
 MAXIMUM ALLOWABLE WORKING PRESSURE / TEMPERATURE RATINGS
 NPT ratings per ASME B31.3-2016; Flange ratings per ASME B16.5-2017**

Body Size	Body Material	End Connection	Pressure psig	Temperature °F	Pressure (Barg)	Temperature (°C)			
1/2"-1" (DN15-DN25)	Cast SST ASTM A351 Grade CF3M *	NPT, Opt-32	1625	-425 to +300	(112)	(-254 to +149)			
			1560	400	(107)	(204)			
			1450	500	(100)	(260)			
			1380	600	(95.1)	(316)			
			1320	700	(91.0)	(371)			
			1280	800	(88.2)	(427)			
			1275	850	(87.9)	(454)			
	Cast Bronze ASTM B62 C83600	NPT	755	-325 to +250	(52.0)	(-198 to +121)			
			710	300	(48.9)	(149)			
			675	350	(46.5)	(177)			
			645	400	(44.4)	(204)			
			640	450	(44.1)	(232)			
	1-1/2" (DN40)	Cast SST ASTM A351 Grade CF3M *	NPT, Opt-32	1460	-425 to +300	(100)	(-254 to +149)		
				1400	400	(96.5)	(204)		
1305				500	(90.0)	(260)			
1240				600	(85.5)	(316)			
1185				700	(81.7)	(371)			
1150				800	(79.3)	(427)			
1145				850	(78.9)	(454)			
Cast Bronze ASTM B62 C83600		NPT	865	-325 to +250	(59.6)	(-198 to +121)			
			810	300	(55.8)	(149)			
			770	350	(53.1)	(177)			
			740	400	(51.0)	(204)			
			730	450	(50.3)	(232)			
			2" (DN50)	Cast SST ASTM A351 Grade CF3M *	NPT, Opt-32	870	-425 to +300	(60.0)	(-254 to +149)
						835	400	(57.5)	(204)
775	500	(53.4)				(260)			
735	600	(50.6)				(316)			
705	700	(48.6)				(371)			
685	800	(47.2)				(427)			
680	850	(46.8)				(454)			
Cast Bronze ASTM B62 C83600	NPT	410		-325 to +250	(28.2)	(-198 to +121)			
		385		300	(26.5)	(149)			
		365		350	(25.1)	(177)			
		350		400	(24.1)	(204)			
		345		450	(23.7)	(232)			
		All		Cast SST ASTM A351 Grade CF3M *	Class 150 RF Flanged	275	-425 to +100	(18.9)	(-254 to +38)
						235	200	(16.2)	(93)
215	300		(14.8)			(149)			
195	400		(13.4)			(204)			
170	500		(11.7)			(260)			
140	600		(9.6)			(316)			
110	700		(7.5)			(371)			
80	800		(5.5)		(427)				
65	850		(4.4)		(454)				
Class 300 RF Flanged	720		-425 to +100		(49.6)	(-254 to +38)			
	620		200		(42.7)	(93)			
	560		300		(38.6)	(149)			
	515		400		(35.5)	(204)			
	480		500		(33.1)	(260)			
	450		600	(31.0)	(316)				
	435		700	(30.0)	(371)				
Class 600 RF Flanged ***	420		800	(28.9)	(427)				
	420		850	(28.9)	(454)				
	1440		-425 to +100	(99.3)	(-254 to +38)				
	1240		200	(85.5)	(93)				
	1120		300	(77.2)	(149)				
	1025		400	(70.6)	(204)				
	955		500	(65.8)	(260)				
Cast SST ASTM A351 Grade CF3M *	Class 150 RF Flanged		900	600	(62.0)	(316)			
			870	700	(60.0)	(371)			
			845	800	(58.2)	(427)			
			835	850	(57.5)	(454)			

* Pressure Rating shall not exceed 375 psig (25.8 Barg) when body material is SST and process medium is oxygen. (CGA G-4.4 2003)
 *** Class 600 RF Flanged ends Not Available in 2" Body Size.

**TABLE 2 - PNEUMATIC ACTUATOR
MAXIMUM PRESSURE DROP – psid (Bard) ¹
Shutoff pressures may be further derated by MAWP
for Size, Body Material, End Connection & Temperature (See Table 1)**

Body Size		Port-Orifice		Pressure Drop		Actuator		Air Supply Pressure			
		Description	Size			Bench Settings				Model	
inch	(DN)		inch	(mm)	psid	(Bard)	psig	(Barg)	psig		(Barg)
1/2", 3/4" & 1"	(15, 20, & 25)	Full (Comp. Only)	.781"	(19.8)	258	(17.8)	5-15	(0.34-1.03)	C27	20	(1.4)
					900	(62)	15-60	(1.03-4.14)		75	(5.2)
					451	(31)	5-15	(0.34-1.03)	C53	20	(1.4)
					1557	(107)	15-60	(1.03-4.14)		75	(5.2)
		Full (Metal Only)	.875	(22.2)	N/A	N/A	5-15	(0.34-1.03)	C27	20	(1.4)
					685	47	15-60	(1.03-4.14)		75	(5.2)
					363	25	5-15	(0.34-1.03)	C53	20	(1.4)
					1156	80	15-60	(1.03-4.14)		75	(5.2)
		Opt.-12 Red.	.500"	(12.7)	631	(44)	5-15	(0.34-1.03)	C27	20	(1.4)
					MAWP		15-60	(1.03-4.14)		75	(5.2)
					1112	(77)	5-15	(0.34-1.03)	C53	20	(1.4)
					MAWP		15-60	(1.03-4.14)		75	(5.2)
1-1/2"	(40)	Full	1.375"	(34.9)	84 *	(5.8) *	5-15	(0.34-1.03)	C27	20	(1.4)
					277	(19.1)	15-60	(1.03-4.14)		75	(5.2)
					147	(10.1)	5-15	(0.34-1.03)	C53	20	(1.4)
					468	(32)	15-60	(1.03-4.14)		75	(5.2)
		Opt.-12 Red.	.781"	(19.8)	258	(17.8)	5-15	(0.34-1.03)	C27	20	(1.4)
					860	(59)	15-60	(1.03-4.14)		75	(5.2)
					456	(31)	5-15	(0.34-1.03)	C53	20	(1.4)
					1452	(100)	15-60	(1.03-4.14)		75	(5.2)
2"	(50)	Full	1.938"	(49.2)	N/A	N/A	5-15	(0.34-1.03)	C27	20	(1.4)
					140	(9.7)	15-60	(1.03-4.14)		75	(5.2)
					74 *	(5.1) *	5-15	(0.34-1.03)	C53	20	(1.4)
					236	(16.3)	15-60	(1.03-4.14)		75	(5.2)
		Opt.-12 Red.	1.688"	(42.9)	N/A	N/A	5-15	(0.34-1.03)	C27	20	(1.4)
					184	(12.7)	15-60	(1.03-4.14)		75	(5.2)
					98	(6.8)	5-15	(0.34-1.03)	C53	20	(1.4)
					311	(21.4)	15-60	(1.03-4.14)		75	(5.2)

* Not Available in Metal Seat.

*** NOTE 1:** Consult factory before applying valves with an I/P Transducer without a positioner. Pressure drop levels may be reduced. Pressure drop values are based on Flow-to-Open (FTO) direction.

**TABLE 3
ROTORK ELECTRIC ACTUATOR
MAXIMUM PRESSURE DROP – psid (Bard)**

Body Size		Port-Orifice Size		Pressure Drop		Actuator	
inch	(DN)	Description	inch	(mm)	psid	(Bard)	Model
1/2"-1"	(15-25)	Full (Comp Only)	0.781	(19.8)	MAWP		CML-750
		Full (Metal Only)	0.875	(22.2)	1526	(105)	CML-750
		Opt.-12 Red.	0.500	(12.7)	MAWP		CML-750
1-1/2"	(40)	Full	1.375	(34.9)	618	(43)	CML-750
		Opt.-12 Red.	0.781	(19.8)	997	(69)	CVL-1500
2"	(50)	Full	1.938	(49.2)	311	(21)	CML-750
					502	(35)	CVL-1500
		Opt.-12 Red.	1.688"	(42.9)	410	(28)	CML-750
					661	(46)	CVL-1500

TABLE 4
FLOW CAPACITY – Cv
EQUAL PERCENT (=%) CHARACTER *
Cv @ 10% TRAVEL INCREMENTS
FL @ 10%; FL @ 100%
METAL SEAT

Body Size inch (DN)	Port Size	FL @ 10% Travel	Minimum Flow	Percent of Travel - %										FL @ 100% Travel
				10	20	30	40	50	60	70	80	90	100	
1/2" (15)	Full	.90	0.14	0.3	0.4	0.7	1.3	2.6	4.8	7.1	8.5	8.8	8.8	.90
	Opt-12 Reduced	.90	0.07	0.1	0.2	0.3	0.4	0.6	0.8	1.2	1.7	2.4	3.5	
3/4" (20)	Full	.90	0.14	0.3	0.5	0.7	1.2	2.3	4.7	7.4	9.5	10.7	11.2	.90
	Opt-12 Reduced	.90	0.07	0.1	0.2	0.3	0.4	0.6	0.8	1.2	1.8	2.5	3.7	
1" (25)	Full	.90	0.14	0.4	0.5	1.0	1.8	3.2	5.5	8.0	9.9	11.2	12	.90
	Opt-12 Reduced	.90	0.07	0.1	0.2	0.3	0.4	0.6	0.9	1.3	1.8	2.6	3.8	
1-1/2" (40)	Full	.90	0.3	0.6	1.0	1.9	3.4	5.6	9.8	13.5	16.1	17.8	18.5	.90
	Opt-12 Reduced	.90	0.19	0.3	0.5	0.7	1.0	1.5	2.2	3.2	4.5	6.6	9.6	
2" (50)	Full	.90	0.7	1.2	2.7	4.1	7.4	12.1	20.4	28.2	33.9	37.6	39	.90
	Opt-12 Reduced	.90	0.5	1.0	1.5	2.1	3.0	4.3	6.2	9.0	12.9	18.6	27.3	
Model 2296HF														
1-1/2" (40)	Full	.90	0.4	0.7	1.0	1.8	3.3	5.6	10.2	14.5	18.1	20.8	22.5	.90
	Opt-12 Reduced	.90	0.2	0.4	0.6	0.8	1.1	1.6	2.3	3.3	4.7	6.8	10	
2" (50)	Full	.90	0.8	1.4	2.0	3.7	6.9	11.6	20.2	29.1	36.1	41.9	44.5	.90
	Opt-12 Reduced	.90	0.5	1.0	1.6	2.3	3.2	4.7	6.6	9.7	14.0	20.2	29.6	

* If replacing an existing Model 2266 with a Model 2296 select linear flow characteristic (trim).

TABLE 5
FLOW CAPACITY – Cv
LINEAR CHARACTER
Cv @ 10% TRAVEL INCREMENTS
FL @ 10%; FL @ 100%
METAL SEAT

Body Size inch (DN)	Port Size	FL @ 10% Travel	Minimum Flow	Percent of Travel - %										FL @ 100% Travel
				10	20	30	40	50	60	70	80	90	100	
1/2" (15)	Full	.90	0.15	3.1	4.7	6.0	7.1	8.0	8.6	9.1	9.4	9.6	9.7	.90
	Opt-12 Reduced	.90	0.07	0.4	0.7	1.1	1.4	1.8	2.1	2.5	2.8	3.1	3.5	
3/4" (20)	Full	.90	0.19	2.9	4.5	5.9	7.1	8.2	9.0	9.8	10.4	10.9	11.2	.90
	Opt-12 Reduced	.90	0.07	0.4	0.7	1.1	1.4	1.8	2.2	2.5	2.9	3.2	3.6	
1" (25)	Full	.90	0.2	2.7	4.3	5.6	6.9	8.1	9.1	10	10.8	11.4	12	.90
	Opt-12 Reduced	.90	0.07	0.4	0.7	1.1	1.4	1.8	2.2	2.5	2.9	3.2	3.6	
1-1/2" (40)	Full	.90	0.3	4.4	6.9	9.1	11.1	12.9	14.4	15.7	16.9	17.8	18.5	.90
	Opt-12 Reduced	.90	0.18	0.9	1.8	2.8	3.7	4.6	5.5	6.4	7.4	8.3	9.2	
2" (50)	Full	.90	0.7	9.2	14.7	19.2	23.4	27	30.2	33	35.3	37.1	38.6	.90
	Opt-12 Reduced	.90	0.5	2.7	5.4	8.1	10.8	13.5	16.1	18.8	21.5	24.2	26.9	
Model 2296HF														
1-1/2" (40)	Full	.90	0.5	5.2	8.3	11.2	13.9	16.4	18.7	20.9	22.8	24.5	26	.90
	Opt-12 Reduced	.90	0.17	1.0	1.9	2.9	3.9	4.9	5.8	6.8	7.8	8.7	9.7	
2" (50)	Full	.90	0.8	9.0	14.6	19.4	24.1	28.3	32.1	35.7	38.9	41.6	44	.90
	Opt-12 Reduced	.90	0.5	2.9	5.8	8.6	11.5	14.4	17.3	20.2	23	25.9	28.8	

TABLE 6
FLOW CAPACITY – Cv
EQUAL PERCENT (=%) CHARACTER *
Cv @ 10% TRAVEL INCREMENTS
FL @ 10%; FL @ 100%
COMPOSITION TFE SEAT

Body Size inch (DN)	Port Size	FL @ 10% Travel	Minimum Flow	Percent of Travel - %										FL @ 100% Travel
				10	20	30	40	50	60	70	80	90	100	
1/2" (15)	Full	.90	0.14	0.2	0.3	0.5	0.9	1.7	2.8	4.5	5.9	6.8	7.1	.90
	Opt-12 Reduced	.90	0.07	0.1	0.2	0.3	0.4	0.6	0.8	1.2	1.8	2.5	3.7	
3/4" (20)	Full	.90	0.14	0.3	0.4	0.6	0.8	1.6	3.1	4.8	6.7	8.2	9.2	.90
	Opt-12 Reduced	.90	0.07	0.1	0.2	0.3	0.4	0.6	0.9	1.3	1.8	2.6	3.8	
1" (25)	Full	.90	0.14	0.4	0.5	0.8	1.5	2.6	4.2	6.4	8.4	10.2	11.5	.90
	Opt-12 Reduced	.90	0.07	0.1	0.2	0.3	0.4	0.6	0.9	1.3	1.8	2.7	3.9	
1-1/2" (40)	Full	.90	0.3	0.6	1.0	1.9	3.4	5.6	9.5	12.9	15.7	17.7	18.5	.90
	Opt-12 Reduced	.90	0.19	0.3	0.5	0.7	1.0	1.5	2.2	3.2	4.5	6.6	9.6	
2" (50)	Full	.90	0.7	1.2	2.7	4.1	7.4	12.1	20	27.3	33.5	37.4	39	.90
	Opt-12 Reduced	.90	0.5	1.0	1.6	2.2	3.1	4.4	6.4	9.3	13.4	19.3	28.2	
Model 2296HF														
1-1/2" (40)	Full	.90	0.4	0.7	1.0	1.8	3.3	5.6	9.8	13.9	17.6	20.6	22.5	.90
	Opt-12 Reduced	.90	0.2	0.4	0.6	0.8	1.1	1.6	2.3	3.3	4.8	6.9	10.1	
2" (50)	Full	.90	0.8	1.4	2.0	3.7	6.9	11.6	19.8	28	35.6	41.2	44.5	.90
	Opt-12 Reduced	.90	0.5	1.1	1.7	2.4	3.3	4.8	7.0	10.1	14.5	21	30.7	

* If replacing an existing Model 2266 with a Model 2296 select linear flow characteristic (trim).

TABLE 7
FLOW CAPACITY – Cv
LINEAR CHARACTER
Cv @ 10% TRAVEL INCREMENTS
FL @ 10%; FL @ 100%
COMPOSITION TFE SEAT

Body Size inch (DN)	Port Size	FL @ 10% Travel	Minimum Flow	Percent of Travel - %										FL @ 100% Travel
				10	20	30	40	50	60	70	80	90	100	
1/2" (15)	Full	.90	0.15	2.0	3.1	4.1	4.9	5.6	6.2	6.7	7.1	7.4	7.6	.90
	Opt-12 Reduced	.90	0.07	0.4	0.7	1.1	1.4	1.8	2.1	2.5	2.8	3.1	3.5	
3/4" (20)	Full	.90	0.19	2.1	3.3	4.4	5.5	6.4	7.3	8.0	8.7	9.3	9.8	.90
	Opt-12 Reduced	.90	0.07	0.4	0.7	1.1	1.4	1.8	2.2	2.5	2.9	3.2	3.6	
1" (25)	Full	.90	0.2	2.1	3.5	4.7	5.9	7.0	8.0	9.0	9.9	10.7	11.5	.90
	Opt-12 Reduced	.90	0.07	0.4	0.8	1.2	1.6	2.0	2.3	2.7	3.1	3.5	3.9	
1-1/2" (40)	Full	.90	0.3	4.4	6.9	9.2	11.1	12.9	14.4	15.7	16.9	17.8	18.5	.90
	Opt-12 Reduced	.90	0.18	0.9	1.9	2.8	3.7	4.7	5.6	6.5	7.4	8.4	9.3	
2" (50)	Full	.90	0.7	9.2	14.7	19.2	23.4	27	30.2	33	35.3	37.1	38.6	.90
	Opt-12 Reduced	.90	0.5	2.8	5.6	8.4	11.2	14	16.7	19.5	22.3	25.1	27.9	
Model 2296HF														
1-1/2" (40)	Full	.90	0.5	5.0	8.1	10.8	13.5	15.9	18.1	20.2	22.3	23.7	25.2	.90
	Opt-12 Reduced	.90	0.17	1.0	2.0	2.9	3.9	4.9	5.9	6.9	7.8	8.8	9.8	
2" (50)	Full	.90	0.8	9.0	14.6	19.4	24.1	28.3	32.1	35.7	38.9	41.6	44	.90
	Opt-12 Reduced	.90	0.5	3.0	6.0	9.0	12	15.1	18.1	21.1	24.1	27.1	30.1	

DIMENSIONS & WEIGHTS PNEUMATIC ACTUATOR

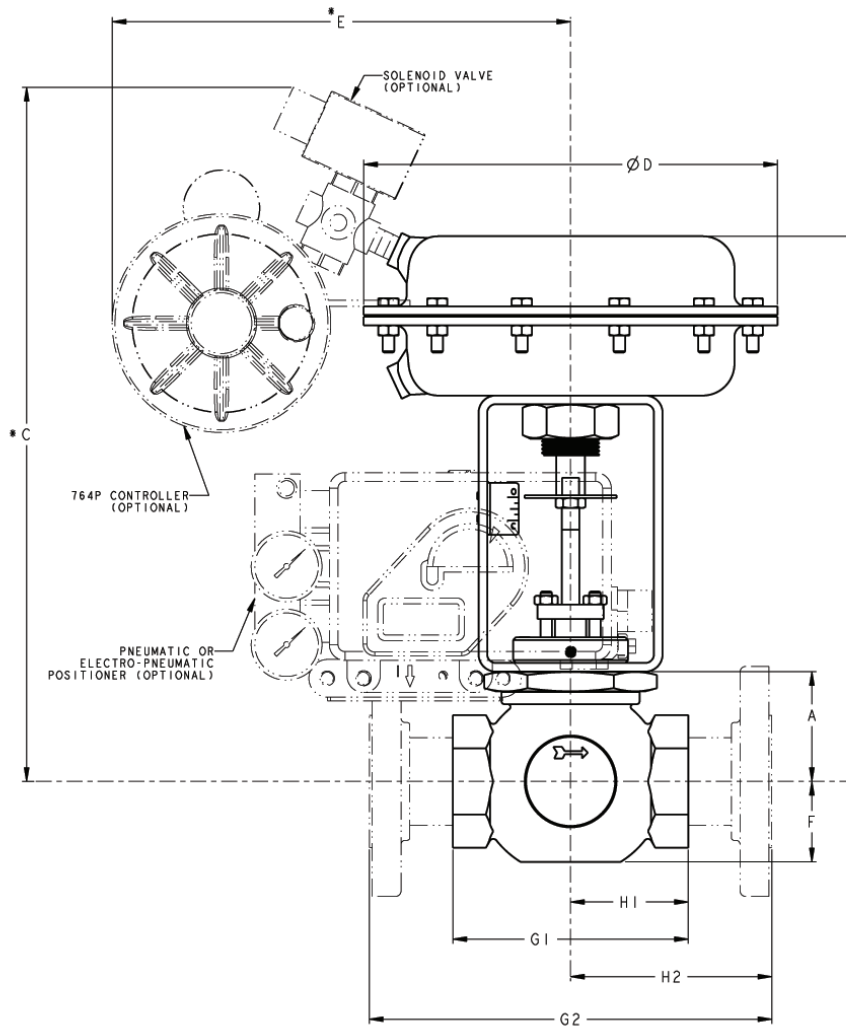

MODEL 2296

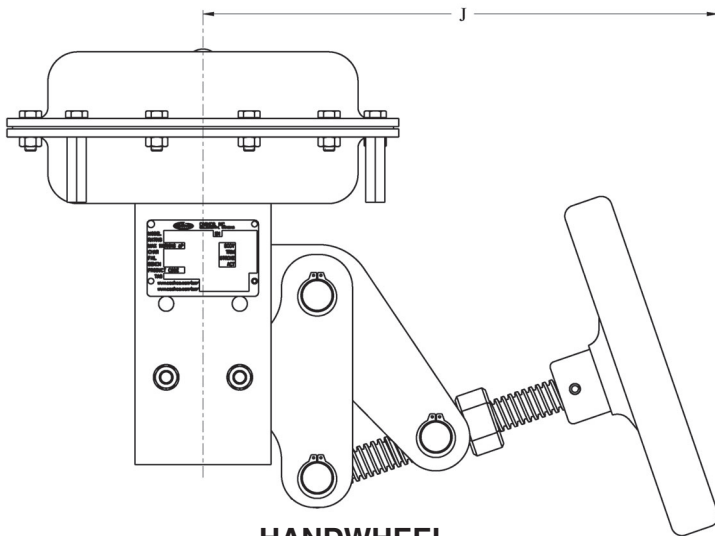

HANDWHEEL

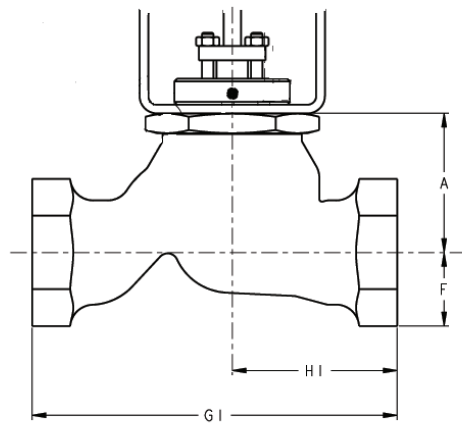

MODEL 2296HF BODY

ENGLISH UNITS – inch & lbs.								
Dimensions		Body Size						
		Model 2296				Model 2296HF		
		1/2"	3/4"	1"	1-1/2"	2"	1-1/2"	2"
A		2.26	2.26	2.26	2.39	3.75	3.01	4.19
w/5" Ext Col		7.46	7.46	7.46	7.58	--	8.20	--
w/12" Ext Col		15.21	15.21	15.21	--	--	--	--
w/15" Ext Col		--	--	--	17.58	20.21	18.20	20.65
C27	B	11.72	11.72	11.72	11.85	13.21	12.47	13.65
	w/5" Ext Col	16.93	16.93	16.93	17.04	--	17.66	--
	w/12" Ext Col	24.67	24.67	24.67	--	--	--	--
	w/15" Ext Col	--	--	--	27.04	29.68	27.66	30.12
	C	14.91	14.91	14.91	15.04	16.40	15.66	16.84
	w/5" Ext Col	20.12	20.12	20.12	--	--	--	--
	w/12" Ext Col	27.86	27.86	27.86	20.23	--	20.85	--
	w/15" Ext Col	--	--	--	30.23	32.87	30.85	33.31
	D	9.00	9.00	9.00	9.00	9.00	9.00	9.00
E	9.97	9.97	9.97	9.97	9.97	9.97	9.97	
C53	B	11.86	11.86	11.86	11.99	13.35	12.61	13.79
	w/5" Ext Col	17.07	17.07	17.07	17.18	--	17.80	--
	w/12" Ext Col	24.81	24.81	24.81	--	--	--	--
	w/15" Ext Col	--	--	--	27.18	29.82	16.58	30.26
	C	15.83	15.83	15.83	15.96	17.32	21.77	17.76
	w/5" Ext Col	21.03	21.03	21.03	21.15	--	20.85	--
	w/12" Ext Col	28.78	28.78	28.78	--	--	--	--
	w/15" Ext Col	--	--	--	31.15	33.79	31.77	34.23
	D	11.56	11.56	11.56	11.56	11.56	11.56	11.56
E	11.21	11.21	11.21	11.21	11.21	11.21	11.21	
F		1.63	1.63	1.63	1.75	2.31	1.59	1.95
G ¹		4.31	4.31	4.31	5.12	6.50	7.88	9.38
G ² OPT-30	150#	7.25	7.25	7.25	8.75	10.00	--	--
	300#	7.50	7.62	7.75	9.25	10.50	--	--
	600#	8.00	8.12	8.25	9.88	--	--	--
G ² OPT-32		7.31	7.31	7.31	8.12	9.50	--	--
H ¹		2.16	2.16	2.16	2.56	3.25	3.56	4.19
H ² OPT-30	150#	3.63	3.63	3.63	4.38	5.00	--	--
	300#	3.75	3.81	3.88	4.63	5.25	--	--
	600#	4.00	4.06	4.13	4.94	--	--	--
H ² OPT-32		3.66	3.66	3.66	4.06	4.75	--	--
J w/C27		12.04	12.04	12.04	12.04	12.04	12.04	12.04
J w/C53		12.50	12.50	12.50	12.50	12.50	12.50	12.50
WEIGHT	Body sub-Assy	6	6	6	10	22	11	25
	w/ C27	26	26	26	30	42	31	45
	w/ C53	38	38	38	42	54	43	57
Add for Ext Col		6	6	6	6	12	6	12
Add for Opt.-30		8	8	8	15	15	--	--

The contents of this publication are presented for informational purposes only, and while every effort has been made to ensure their accuracy, they are not to be construed as warranties or guarantees, express or implied, regarding the products or services described herein or their use or applicability. We reserve the right to modify or improve the designs or specifications of such product at any time without notice. Cashco, Inc. does not assume responsibility for the selection, use or maintenance of any product. Responsibility for proper selection, use and maintenance of any Cashco, Inc. product remains solely with the purchaser.

METRIC UNITS – mm & kg.								
Dimensions		Body Size - DN						
		15	20	25	40	50	40	50
		Model 2296					Model 2296HF	
A		57.4	57.4	57.4	60.7	95.3	76.5	106.4
w/5" Ext Col		189.5	189.5	189.5	192.5	--	208.3	--
w/12" Ext Col		386.3	386.3	386.3	--	--	--	--
w/15" Ext Col		--	--	--	446.5	513.3	462.3	524.5
C27	B	297.7	297.7	297.7	301.0	335.5	316.7	346.7
	w/5" Ext Col	430.0	430.0	430.0	432.8	--	448.6	--
	w/12" Ext Col	626.6	626.6	626.6	--	--	--	--
	w/15" Ext Col	--	--	--	686.8	753.9	702.6	765
	C	378.7	378.7	378.7	382.0	416.6	397.8	427.7
	w/5" Ext Col	511.0	511.0	511.0	--	--	--	--
	w/12" Ext Col	707.6	707.6	707.6	513.8	--	529.6	--
	w/15" Ext Col	--	--	--	767.8	834.9	783.6	846.1
	D	228.6	228.6	228.6	228.6	228.6	228.6	228.6
E	253.2	253.2	253.2	253.2	253.2	253.2	253.2	
C53	B	301.2	301.2	301.2	304.5	339.1	320.3	350.3
	w/5" Ext Col	433.6	433.6	433.6	436.4	--	452.1	--
	w/12" Ext Col	630.2	630.2	630.2	--	--	--	--
	w/15" Ext Col	--	--	--	690.4	757.4	421.1	768.6
	C	402.1	402.1	402.1	405.4	439.9	553	451.1
	w/5" Ext Col	534.2	531.2	534.2	537.2	--	529.6	--
	w/12" Ext Col	731	731	731	--	--	--	--
	w/15" Ext Col	--	--	--	791.2	858.3	807	869.4
	D	293.6	293.6	293.6	293.6	293.6	293.6	293.6
E	284.7	284.7	284.7	284.7	284.7	284.7	284.7	
F		41.4	41.4	41.4	44.5	58.7	40.4	49.5
G ¹		109.5	109.5	109.5	130.0	165.1	200.2	238.3
G ² Opt-30	150#	184.2	184.2	184.2	222.3	254.0	--	--
	300#	190.5	193.5	196.9	235	266.7	--	--
	600#	203.2	206.2	209.6	251	--	--	--
G ² Opt-32		185.7	185.7	185.7	206.2	241.3	--	--
H ¹		54.9	54.9	54.9	65.0	82.6	90.4	106.4
H ² Opt-30	150#	92.2	92.2	92.2	111.3	127.0	--	--
	300#	95.3	96.8	98.6	117.6	133.4	--	--
	600#	101.6	103.1	104.9	125.5	--	--	--
H ² Opt-32		93.0	93.0	93.0	103.1	120.7	--	--
J w/C27		305.8	305.8	305.8	305.8	305.8	305.8	305.8
J w/C53		317.5	317.5	317.5	317.5	317.5	317.5	317.5
WEIGHT	Body sub-Assy	2.8	2.8	2.8	4.5	10	5	11.3
	w/ C27	11.8	11.8	11.8	13.6	19.1	14.1	20.4
	w/ C53	17.2	17.2	17.2	19.1	24.5	19.5	25.9
Add for Ext Col		2.7	2.7	2.7	2.7	5.4	2.7	5.4
Add for Opt.-30		3.6	3.6	3.6	6.8	6.8	--	--

DIMENSIONS & WEIGHTS ROTORK ELECTRIC ACTUATOR

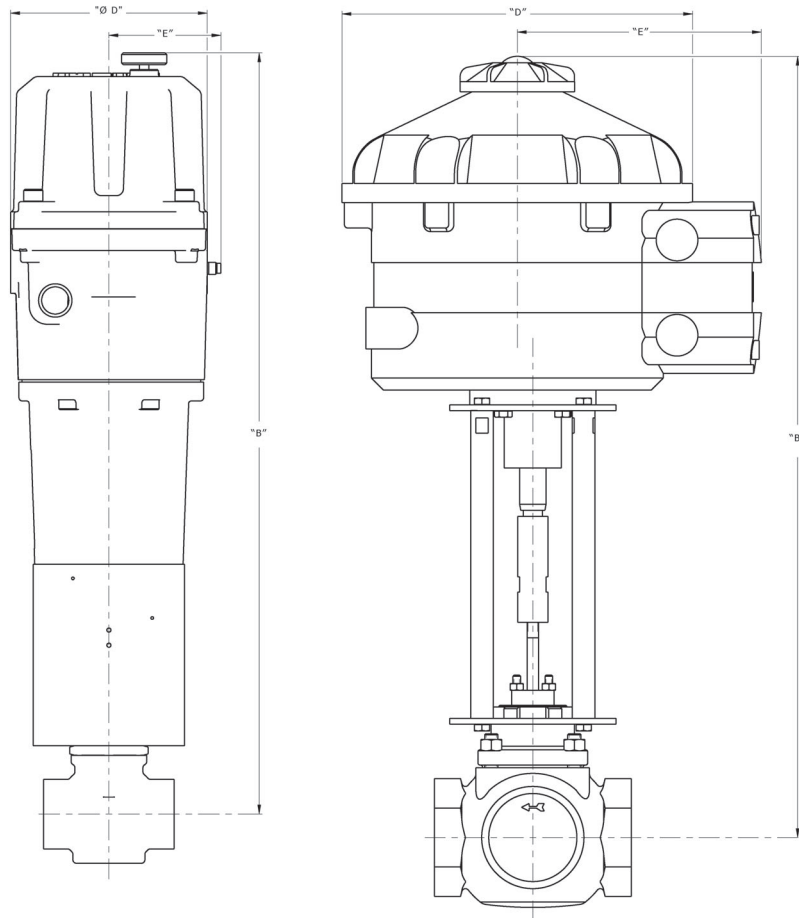

ENGLISH (METRIC) UNITS – inch & lbs.(mm & kg)								
Dimensions		Body Size						
		Model 2296					Model 2296HF	
		1/2" (15)	3/4" (20)	1" (25)	1-1/2" (40)	2" (50)	1-1/2" (40)	2" (50)
CML750	B	20.35 (516.9)	20.35 (516.9)	20.35 (516.9)	20.48 (520.2)	21.84 (554.7)	21.10 (535.9)	22.28 (565.9)
	w/5" Ext Col	25.55 (649)	25.55 (649)	25.55 (649)	25.67 (652)	--	26.29 (667.8)	--
	w/12" Ext Col	33.30 (845.8)	33.30 (845.8)	33.30 (845.8)	--	--	--	--
	w/15" Ext Col	--	--	--	35.67 (906)	38.30 (972.8)	36.29 (921.8)	38.74 (984)
	D	7.91 (200.9)	7.91 (200.9)	7.91 (200.9)	7.91 (200.9)	7.91 (200.9)	7.91 (200.9)	7.91 (200.9)
E	7.40 (188)	7.40 (188)	7.40 (188)	7.40 (188)	7.40 (188)	7.40 (188)	7.40 (188)	
CVL1500	B	--	--	--	19.98 (507.5)	21.34 (542)	20.60 (523.2)	21.78 (553.2)
	w/5" Ext Col	--	--	--	25.17 (639.3)	--	25.79 (655.1)	--
	w/12" Ext Col	--	--	--	--	--	--	--
	w/15" Ext Col	--	--	--	35.17 (893.3)	37.80 (960.1)	35.78 (908.8)	38.24 (971.3)
	D	10.25 (260.4)	10.25 (260.4)	10.25 (260.4)	10.25 (260.4)	10.25 (260.4)	10.25 (260.4)	10.25 (260.4)
E	15.39 (390.9)	15.39 (390.9)	15.39 (390.9)	15.39 (390.9)	15.39 (390.9)	15.39 (390.9)	15.39 (390.9)	
WEIGHT	CML-750	37 (16.8)	37 (16.8)	37 (16.8)	41 (18.6)	53 (24)	42 (19.1)	56 (25.4)
	CVL-1500	--	--	--	71 (32.2)	83 (37.6)	72 (32.7)	86 (39)
Add for Ext Col		6 (2.7)	6 (2.7)	6 (2.7)	6 (2.7)	12 (5.4)	6 (2.7)	12 (5.4)
Add for Opt.-30		8 (3.6)	8 (3.6)	8 (3.6)	15 (6.8)	15 (6.8)	--	--

MODEL 2296 PRODUCT CODER 05/06/19

An "X" in POS 12 followed by a 5-digit control number overrides remaining selections.



POSITION 3 - BODY			
2296 Size		Material	
		BRZ	SST
in	(DN)	CODE	
1/2"	(15)	4	A
3/4"	(20)	5	B
1"	(25)	6	C
1-1/2"	(40)	8	D
2"	(50)	9	E
2296HF			
1-1/2"	(40)	1	
2"	(50)	2	

POSITION 5 - END CONNECTIONS	
Connection	CODE
NPT-Screwed	1
Extended Pipe Nipples Opt-32 *	2
150 # RF Flanged Opt-30 *	3
300 # RF Flanged Opt-30 *	4
600 # RF Flanged Opt-30 *	5

*Opt. -30 & -32 - SST Body Only
600#RF not available in 2" size

POSITION 6 - CHARACTERISTIC/PORT SIZE/TRIM					
Inherent Character	Port Size	TRIM *			
		S1	MB1	S3	MB3
CODE					
Equal %	Full	1	R	5	L
	Full & Opt-15 Stellite	A			
	Opt.-12 Red.	2	T	6	M
Linear **	Full	3	V	7	N
	Full & Opt-15 Stellite	B			
	Opt.-12 Red.	4	Y	8	P

* Refer to Position 11 for *** notation.
** Select Linear Trim when replacing a Model 2266 Control Valve

POSITION 8 - Product Classification Under European "Pressure Equipment Directive"		
PRODUCT DESTINATION	HAZARD CATEGORY	CODE
Anywhere except Europe	N/A	7
European Countries * (CE Mark does not apply to DN25 and below)	Sound Engineering Practice (SEP)	S
	CE Marked Hazard Cat I or II	E

* For products to be placed in service in Europe - Ref to Directive 2014/68/EU.
Forward Completed "EU" Application Recorder prior to quotation. (Without Recorder- Processing of Purchase Order will be delayed). Contact Cashco for Assistance.

POSITION 10 - CONSTRUCTION			
Construction	Sizes	CODE	CODE
Standard	All	0	
Cryogenic	Sizes	Opt-5N_ *	Opt-5_ or -36_
5" Ext. Column ("G" Only)	1/2"-1-1/2"	1	A
12" Ext. Column ("L")	1/2" - 1"	2	B
15" Ext. Column ("L")	1-1/2" - 2" 2296 & 2296HF **	3	C

* Bronze Body material only.
** 2296HF Bronze body material only.
Opt-5N_ includes Opt-56 (Selection 0 from Position 17)
Opt-5_ / -36_ includes Opt-55 (Selection 0 from Position 17)
*G" = Gaseous, "L" = Liquid Service

POSITION 11 - ACTUATOR MODEL / BENCH SET RANGE & ACTION *				
Model	5-15 psig **		15-60 psig	
	ATO FC	ATC FO	ATO FC	ATC FO
CODE				
C27	A	1	B	2
C53	3	5	4	6
No Act. Body Assy Only	0			
Electric Act. ***	24 DC		110 AC	
	CODE			
CML 750	R		T	
CVL 1500	S		U	

* Refer back to TB Table 2 - Max. Shutoff Pressure to confirm selection of Act. Model above & Trim for Position 6.
** Not available for C27 Act. all sizes, full port with metal seat.
*** Includes Positioner w/ Hart Communication; must pick code "0" in Position 12, 13, 14, and 15.

POSITION 12 - 764 * (Bracket Mtd) - ADDITIONAL Airset (Bracket Mtd) - SOLENOID VALVE			
764P or 764T / Action	Solenoid Valve *** Exhaust on Deenergization		
	None	120VAC 60 Hz	24 VDC
CODE			
None	0	6	C
Reverse **	2	8	E
Reverse W/ Airset **	3	9	F
Direct **	4	A	G
Direct W/ Airset **	5	B	H
Special Construction Contact Cashco for Code	X		

* Refer to 764-TB for Product Code of Controller.
** Select Code 1 on Position 13 if positioner is needed.
***Solenoid rated as 4/4X only.

BALANCE OF PRODUCT CODE POSITIONS "13 - 17" ON FOLLOWING PAGE.

POSITION 13 - DIRECT ACTING POSITIONER with AIRSET (Bracket Mounted) (3-15 psig) 4-20 mA Code for Split Range in Position 16					
Positioner Model	Ratings	Analog/Digital	Hart	Fieldbus	Profibus
		CODE			
P5 P/P *	Gen. Purpose	1			
D20 D I/P	Gen. Purpose	C	D		
D20 I I/P *	Intrinsically Safe	2	5		
D20 E I/P ***	Explosion Proof	E	F		
D3 X I/P	Gen. Purpose	L	M	N	P
D3 I I/P	Intrinsically Safe	3	6	8	A
D3 E I/P ****	Explosion Proof	G	H	J	K
PS2-1 I/P	Gen. Purpose		R	S	T
PS2-2 I/P	Intrinsically Safe		7	9	B
PS2-3 I/P ***	Explosion Proof		U	V	W
None **		0			

* Stock Item
 ** Actuator Assembly includes dimensions for (Namur) Mounting per IEC 60534-6-1.
 *** Not available with limit/proximity switch option. Choose codes "8", "9" or "0" in Pos. 15.
 **** Not available with options. Please select code "0" in Pos. 15.

POSITION 14 - GAUGE BLOCK	
Option for Positioner	Code
None *	0
Gauge Block **	1

* For P5 gauge ports built in. No gauges.
 * For D20 E, D3 E & PS2-3 gauge block is standard. No gauges
 ** For D20 D & D20 I and PS2-1 & PS2-2 - gauge block with gauges.
 ** For D3 X & D3 I gauge block only - no gauges.

POSITION 16 - OPTIONS			
Accessories	CODE	Split Range Options for Positioner	
		(3-9 psig) 4-12 mA	(9-15 psig) 12-20 mA
No Handwheel	0	1	2
Handwheel	9	A	B

*CML actuators come standard with manual override handwheel; Code 9 must be selected.

POSITION 15 - POSITIONER OPTIONS							
Options	POSITIONERS			I/P TRANSDUCERS *			
	Inductive Limit Switches	Micro-switches Limit Switches	Position Transmitter	3-15 PSIG No Airset	3-15 PSIG W/ Airset	0-60 PSIG No Airset	0-60 PSIG W/ Airset
				CODE			
P5				4	5		
D3 & D20	7	T	9				
PS2			8				
No Positioner				C	F	R	S
None	0						

* For 0-60 Psig Transducer please contact the factory.

POSITION 17 - PAINTING & CLEANING					
Painting	Opt.	Std. Cleaning	Opt-56	Opt - 55	Opt-40
			Cleaned to Spec. #S-1542	Cleaned to Spec. #S-1134 (O2 Cleaned)	NACE
CODE					
Standard	—	0	3	6	J
Epoxy Paint Per Cashco Spec #S-1547	-95	1	4	7	K

Cashco, Inc.
 P.O. Box 6
 Ellsworth, KS 67439-0006
 PH (785) 472-4461
 Fax. # (785) 472-3539
 www.cashco.com
 email: sales@cashco.com
 Printed in U.S.A. 2296-TB

Cashco GmbH
 Handwerkerstrasse 15
 15366 Hoppegarten, Germany
 PH +49 3342 30968 0
 Fax. No. +49 3342 30968 29
 www.cashco.com
 email: germany@cashco.com

Cashco do Brasil, Ltda.
 Al.Venus, 340
 Indaiatuba - Sao Paulo, Brazil
 PH +55 11 99677 7177
 Fax. No.
 www.cashco.com
 email: brazil@cashco.com