



Badger Meter Europa

Badger Meter Europa GmbH
Nürtinger Str. 76
72639 Neuffen (Germany)
Tel. +49-7025-9208-0
Fax +49-7025-9208-15
www.badgermeter.de
badger@badgermeter.de



Barstock control valve RC250



Description

- Control valve in sizes 1", 3/4", 1/2" and 1/4"
- Globe barstock body
- Maximum allowable pressure 340 bar
- Suitable for control of medium and low flow
- A large number of materials of construction
- Many variations not listed here

Application

Suitable for control of liquids, gases or steam, in industrial applications, research, and process pilot plants. Its compact size makes it an ideal choice for additive injection, sampling, low flow hydraulic systems or wherever precise control is an important factor or physical constraints limit valve weight or size.

Connections

Standard is NPT-internal thread.
For other types, see **Data Sheet CON**.

Guiding

Standard as in picture 1 or optional medium and heavy duty guiding **Data Sheet GDG**.

Bonnet

Standard as in picture 1. Other types available as for example:
Cooling fin bonnet **Data Sheet CFG**
Bellows sealed bonnet **Data Sheet BLW**

Packing

Standard are PTFE chevron rings.
For other type, see Data Sheet PCK

Pneumatic actuator

Die cast Aluminium with Epoxy paint, optional 316L S/S (Stainless Steel) but only for 1/2" valves.
Standard actuator "Spring to close" **Data Sheet AC-OS**
Standard actuator "Spring to open" **Data Sheet AC-CS**
With integrated pneumatic positioner:
Standard actuator "Spring to close" **Data Sheet AC-OP**
Standard actuator "Spring to open" **Data Sheet AC-CP**
Various accessories on request.

Electric actuator

Various special types available: explosion proof,
Safety position "Spring to open" or "Spring to close".
Electric **Data Sheet AC-HH500 AC-M60WE**
Electronic **Data Sheet AC-EVA1 AC-MC60**

Dimensions

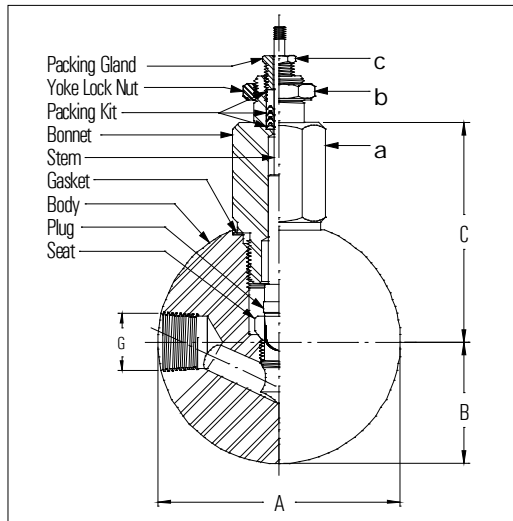

G	A	B	C	D	E	F	Hub
1" NPT*	127	42	100	1-3/4"	1-1/8"	1/2"	14,3
3/4"NPT*	108	54	98	1-1/2"	1-1/8"	1/2"	14,3
1/2"NPT*	83	39	73	1-1/4"	1-1/8"	1/2"	14,3
1/4"NPT*	57	28	47	7/8"	7/8"	7/16"	11.1

Valve materials

Body	Bonnet
1.4571 barstock	1.4571 barstock
1.4539 barstock	1.4539 barstock
316 SST barstock	316 SS barstock
Monel barstock	Monel barstock
Alloy-20 barstock	Alloy20 barstock
Alloy-B barstock	Alloy-B barstock
Alloy-C barstock	Alloy-C barstock

Innervel materials

Size	Plug	Seat
V - 0	316 SST	316 SS
V - P18	Stellite ⁽¹⁾	416 SS
V - P18	Stellite ⁽¹⁾	316 SS stellite
A - 0	Tantalum	Tantalum
V - P5	Monel	Monel
V - P9	Alloy-20	Alloy-20
V - P9	Alloy-B	Alloy-B
V - P13	Alloy-C276	Alloy-C276
V - P13	Additional Titanium nitride coating	

Other materials available on request. Up to now over 140 materials and materials combinations have been used. (316 SS ~ 1.4571).

⁽¹⁾ Stellite[®] is a registered trademark of Deloro Stellite Holdings Corporation.

Pressure-temperature rating body

	°C	1.4571	1.4539	Alloy-B	Alloy-C	Monel	Alloy20	Length bonnet
1" CONTROL VALVE	20	100	100	100	100	82	100	STD
	100	93	89	89	89	69	89	
	200	82	78	78	78	59	78	
	CF	300	55	48	48	48	34	48
		400	17	12	12	8	13	
		500	-	-	-	-	-	
600	-	-	-	-	-			
3/4" CONTROL VALVE	20	100	100	100	100	82	100	STD
	100	99	95	95	95	74	95	
	200	82	78	78	78	59	78	
	CF	300	73	64	64	64	45	64
		400	48	36	36	22	36	
		500	-	-	-	-	-	
600	-	-	-	-	-			
1/2" CONTROL VALVE	20	345	345	345	345	276	345	STD
	100	324	345	345	345	258	344	
	200	269	345	345	345	236	335	
	CF	300	242	336	336	336	234	302
		400	226	311	311	184	382	
		500	191	-	285	116	174	
600	-	-	231	-	-			
1/4" CONTROL VALVE	20	345	345	345	345	276	345	STD
	100	343	345	345	345	275	345	
	200	292	345	345	345	260	325	
	CF	300	267	335	335	335	258	295
		400	249	329	329	249	262	
		500	159	-	299	128	174	
600	-	-	237	-	-			

max. pressure in bar

STD = standard bonnet. Details about bonnet length CF and EF, see **Data Sheet CFG**.

The above pressure ratings alone are not sufficient to determine if a valve is suitable for an application.

You can find help for selection of innervel, material combinations, guiding, bonnet and actuator in the "instruction for valve selection" and the Data Sheets TRM, GDG, CFL resp. AC.



Innervolve chart

NW	Size	Cvs	NW	Size	Cvs
	V	6,0		O	0,003
	U	5,0		P1	2,0 E-03
	T	4,5		P2	1,3 E-03
	S	4,0		P3	1,0 E-03
	R	3,5		P4	6,0 E-04
	A	2,5		P5	4,0 E-04
	B	2,0		P6	2,7 E-04
	C	1,25		P7	1,8 E-04
	D	0,80		P8	1,2 E-04
	E	0,50		P9	8,0 E-05
	F	0,32		P10	5,0 E-05
	G	0,20		P11	3,6 E-05
	H	0,13		P12	2,4 E-05
	I	0,08		P13	1,6 E-05
	J	0,05		P14	1,0 E-05
	K	0,03		P15	6,0 E-06
	L	0,02		P16	4,0 E-06
	M	0,01		P17	2,7 E-06
	N	0,006		P18	1,8 E-06

Size	1"	3/4"	1/2"	1/4"

For detailed information, see Data Sheet TRM.

Innervolve characteristic

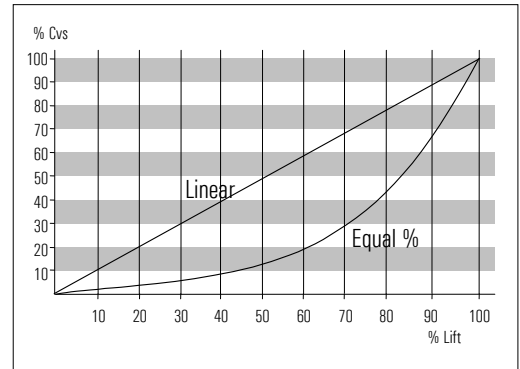

Seat leakage

0.01% of Cvs for "O" and larger ANSI Class IV
 0.1% of Cvs for "P1" and smaller ANSI Class III
 Optional: Metallic or soft seated (PTFE or Kel-F).